

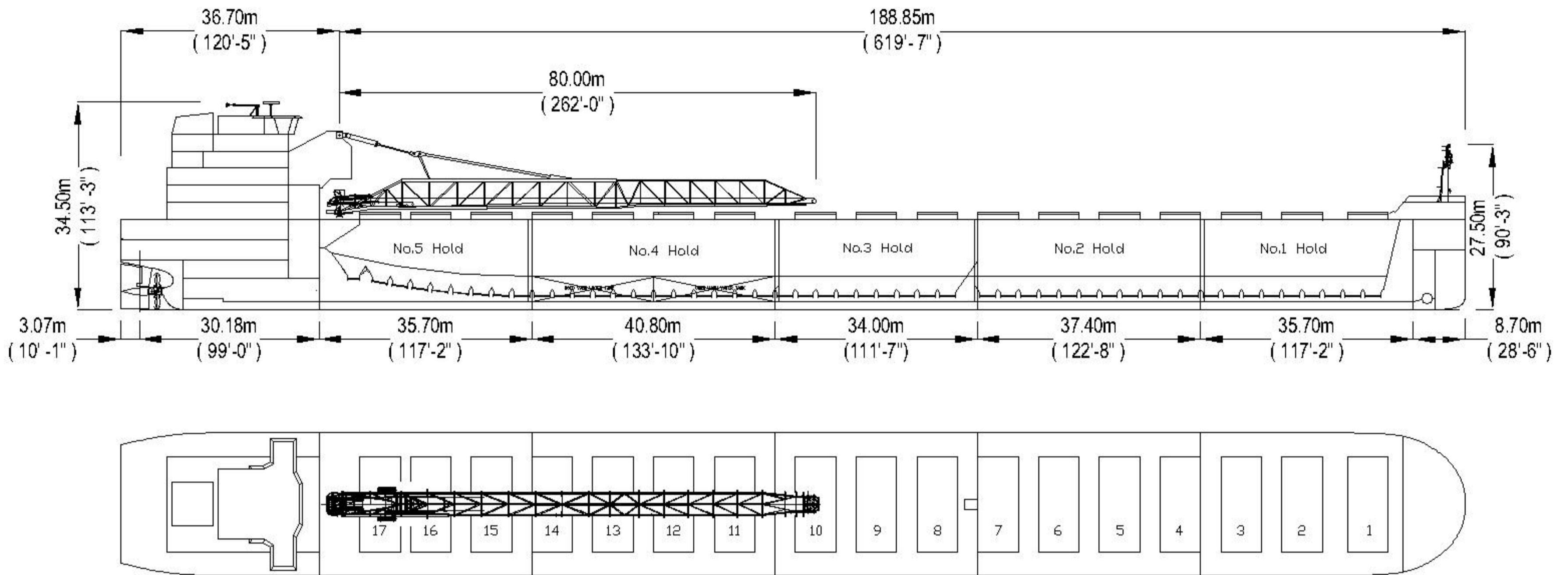

Algoma Conveyor



Manager: Algoma Central Corporation
 Registry: St. Catharines / Canada
 Builder: Yangzijiang Shipbuilding (MD 153)
 Type: Great Lakes Self-Unloading Bulk Carrier
 Class: Lloyds Register of Shipping
 ✕100A1 Great Lakes & River St Lawrence

Principal Particulars

	Metres	Feet
LOA	225.55 m	740'-0"
LBP	222.48 m	729'-11"
Beam (mld)	23.770 m	78'-0"
Depth (mld)	14.700 m	48'-3"

Tonnage

	International
Gross	24640
Net	8970

Great Lakes Load Lines

	Metres	Feet
MS (FW)	9.75	32'- 0"
S (FW)	9.52	31'- 3"
INT (FW)	9.41	30'-11"
W (FW)	9.30	30'- 6"
MS (SW)	9.54	31'- 3"
S (SW)	9.30	30'- 6"
INT (SW)	9.19	30'- 2"
W (SW)	9.08	29'-10"

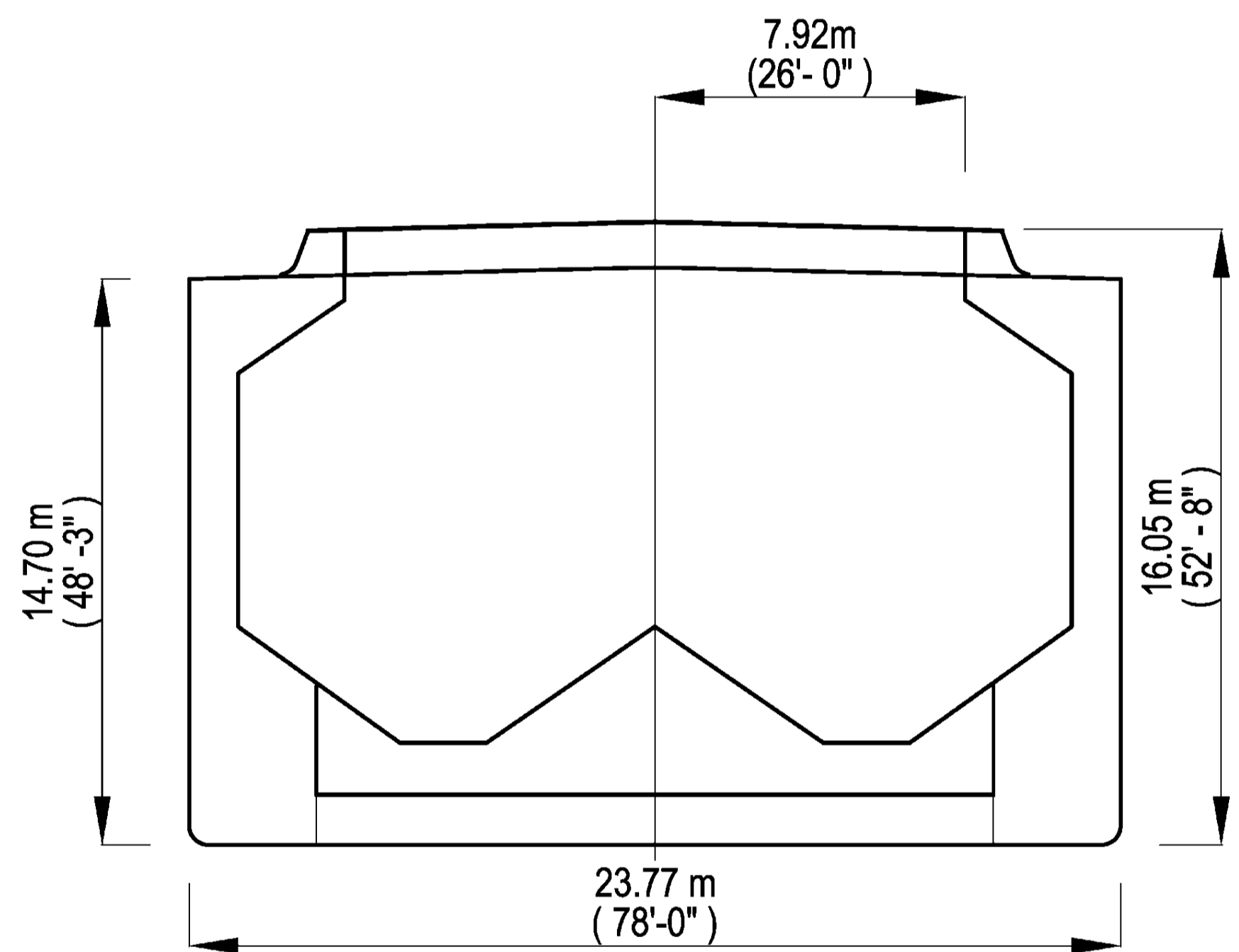

Self Unloading Equipment

Two belt gravity system with loop belt elevator. 80 m discharge boom luffing to 18° and slewing to 90° P&S. Shear type basket gates, UHMW plastic linings in holds and vibrators throughout tunnels. Designed discharge rate of up to 5,400 metric tons/hour.

Cargo Deadweight

	Metric	Long
(610 MT consumables assumed)		
@ Mid Summer	36,800	36,200
@ 26'- 6" (FW) Seaway Draft	28,200	27,750

Note: Deadweight shown excludes Crew & Effects, Fuel Oil, Lube Oil, Water & Stores (~610 MT).

Midship Air Draft

(To Top of Hatch Coaming at Side)

	Metres	Feet
Summer (FW) (9.514 m)	6.53	21'- 6"
Seaway (FW) (8.077 m)	7.97	26'- 2"
Ballast (FW) (5.745 m)	10.31	33'-10"

Hold Capacities (Self-Trim 35°)

	m ³	ft ³
Hold 1	7,200	254,300
Hold 2	8,800	310,800
Hold 3	7,500	264,900
Hold 4	9,500	335,500
Hold 5	6,500	229,500
Total, holds and hatches	39,500	1,395,000

Hatches

Number:	17	
	6.8m x 15.84m	
Type:	Single plate	
	Metres	Feet
Bow to mid Hatch #1	16.50 m	54'- 2"
Fwd to Aft	165.75 m	543'-10"
Mid Hatch #17 to Stern	43.50 m	142'- 9"

63 Church Street, Suite 600 St. Catharines, Ontario
 L2R 3C4 Tel: 905.687.7888 Fax: 905.687.7840
www.algonet.com