

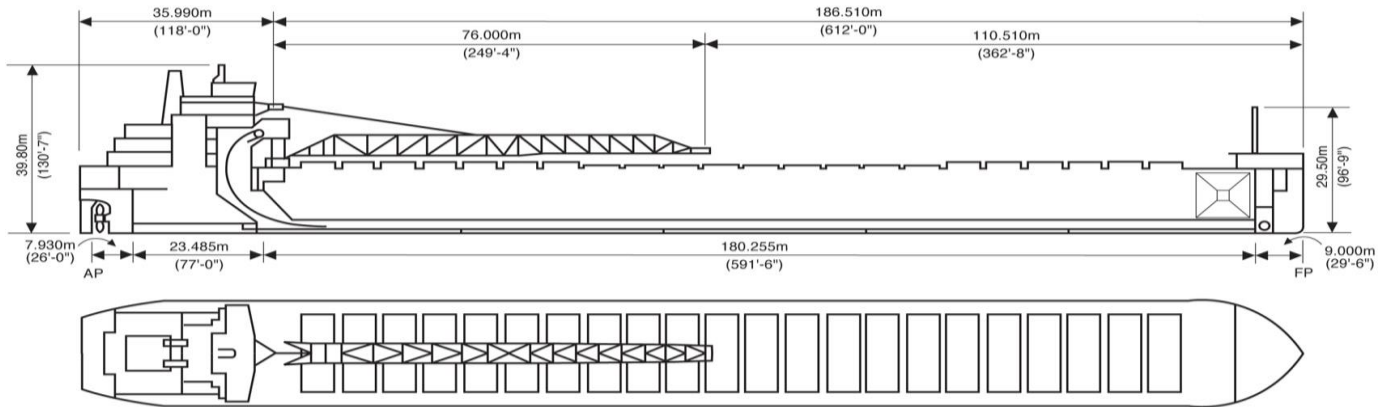

Algoma Transport

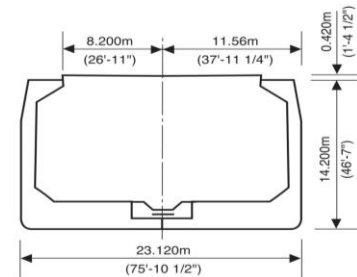

Manager: Algoma Central Corporation
 Registry: Toronto / Canada
 Builder: Port Weller Dry Docks, 1979, Hull 64
 Type: Great Lakes Self Unloading Bulk Carrier
 Class: Lloyds Register of Shipping
 ✱100A1 Great Lakes & River St Lawrence service ✱LMC



Principal Particulars

	Metres	Feet
LOA	222.50 m	730'- 0"
LBP	220.68 m	724'- 0"
Beam (mld)	23.12 m	75'- 10½"
Depth (mld)	14.20 m	46'- 7"

Tonnage

	Cdn	US
Gross	23,399	21,227
Net	16,172	

Assigned Drafts

	Metres	Feet
Mid Summer (FW)	9.389	30' - 9⅝"
Mid Summer (SW)	9.176	30'- 1¼"
Summer (FW)	9.160	30' - 0⅝"
Summer (SW)	8.947	29'- 4¼"
Intermediate (FW)	9.055	29'- 8½"
Intermediate (SW)	8.842	29' - 0⅛"
Winter (FW)	8.950	29' - 4⅜"
Winter (SW)	8.737	28' - 8"

Self Unloading Equipment

Single belt gravity system with reclaiming machine and loop belt elevator. 76.2 m discharge boom luffing to 18° and slewing to 100° P&S. Designed discharge rate of up to 6,096 metric tons/hour.

Cargo Deadweight

(610 MT consumables assumed)

	Metric	Long
MS (FW)	33,203	32,678
26'-6" (FW) Seaway Draft	26,815	26,391

Note: Deadweight shown excludes Crew & Effects, Fuel Oil, Lube Oil, Water & Stores (~610 MT).

Midship Air Draft

(To Top of Hatch Coaming at Side)

	Metres	Feet
Summer (FW) (9.160 m)	5.512 m	18'- 1"
Seaway (FW) (8.077m)	6.595 m	21'- 7⅝"
Ballast (FW) (5.680 m)	8.992 m	29'- 6"

Hold Capacities

	m ³	ft ³
Hold 1	40,390	1,426,359
Total, holds and hatches	40,390	1,426,359

Hatches

Number: 22
Type: Single plate

	Metres	Feet
Bow to mid Hatch #1	25.45	83.50
Fwd to Aft	153.62	504.00
Mid Hatch #22 to Stern	43.43	142.50

63 Church Street Suite 600 St. Catharines, Ontario L2R

3C4 Tel: 905.988.2600 Fax: 905.988.1801

www.algonet.com